

**Transient Voltage
Surge Suppressors By:**

ST-CXBNC##Ex-B



"Power Quality is our Only Business"

P.O. Box 330607
Ft. Worth, TX 76163
Phone: 817.483.8497
Fax: 817.572.2242
www.sinetamer.com

The Coaxial Series devices are designed to protect Data and Signal Transfer circuits, LANs operating Thin Ethernet / ThinNet (10Base2), Token Ring (802.5), 802.3, CCTV, CATV, cable TV, Radio Frequency Receiving Equipment, Coax Satellite Systems, and a wide variety of similar circuits using coaxial connections. This device is connected in series using common BNC coaxial connectors, making your installation a breeze. A ground lug is provided on the side of the unit to insure a low impedance ground discharge path.

The unique design of these devices makes them among the most versatile TVSS devices on the market with superior performance specs and a warranty that is second to none.

GENERAL	
Description:	Series connected transient voltage surge suppressor with Optimal Response Network™ circuitry for use on a wide variety of circuits using coaxial connections.
Application:	Data and Signal Transfer circuits, LANs operating Thin Ethernet / ThinNet (10Base2), Token Ring (802.5), 802.3, CCTV, CATV, cable TV, Radio Frequency Receiving Equipment, Coax Satellite Systems, and a wide variety of similar circuits using coaxial connections.
Warranty:	25 Years Unlimited Free Replacement
Unit Listing:	UL497B

MECHANICAL	
Enclosure:	Die-cast aluminum alloy (Shielded) case
Connection Method:	Input: female, Output: female, Ground: #10 threaded stud, Optional DIN mounting foot.
Shipping Weight:	< 1 lb

CIRCUITRY	
Circuit Design:	Series wired, hybrid, low capacitance design using our Optimal Response Network™ design to provide the lowest possible Let-Through-Voltages.
Protection Modes:	L-G (Common Mode)

PERFORMANCE	
Maximum Continuous Operating Voltage:	7.5, 15, 36, 62, and 140 V
Maximum Continuous Operating Current:	500 mA
Frequency Range:	DC (0 Hz.) Up to 1.5 GHz
Data Signal Rate Range:	0 to 150 Mbps
Series Resistance:	0 Ohms
Characteristic Line Impedance (Z₀):	50 Ohms, resistive
Insertion Loss:	< 3 dB, DC to 1.5 GHz.
Application Range:	50 – 75 Ohms, typical.
Peak Surge Current per coaxial cable:	10 kA PSC (L-G)

Maximum Continuous Operating Voltage Current and Maximum Data Transmission Rate				
Model	MCOV	MCOC	Maximum Data Transmission Rate	Frequency Range
ST-CXBNC5Ex-B	7.5 V	500 mA	≤ 150 Mbps	≤ 1.5 GHz
ST-CXBNC12Ex-B	15 V			
ST-CXBNC24Ex-B	36 V			
ST-CXBNC48Ex-B	62 V			
ST-CXBNC140Ex-B	140 V			

Single Port Coax Model – E1

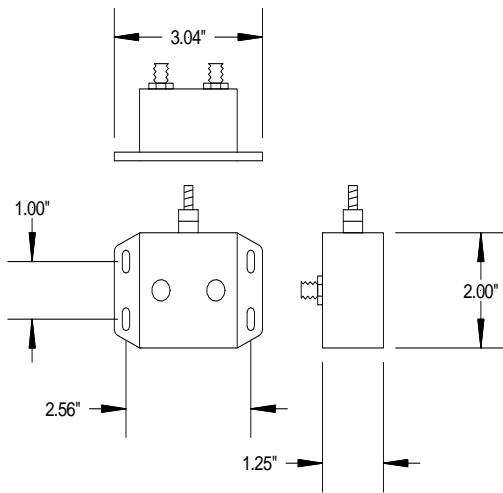

Dual Port Coax Models – E2

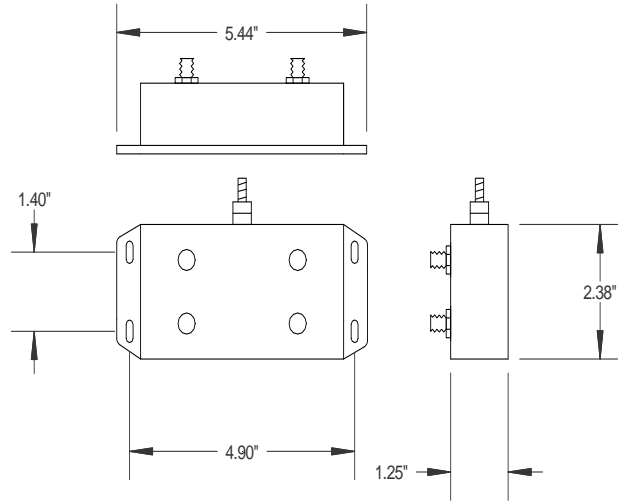

Actual unit may vary from units pictured