



"Power Quality is our Only Business"

P.O. Box 330607
Ft. Worth, TX 76163
Phone: 817.483.8497
Fax: 817.572.2242
www.sinetamer.com

The SineTamer® RM series of units blends outstanding high-energy "impulse" suppression with excellent "ring-wave" transient protection utilizing our Frequency Attenuation Network®. This durable device is intended for general purpose and sensitive/critical load applications. The RM-ST120 is typically installed at small service entrances up to 800 amps, distribution and sub-distribution panels. The circuit design of the RM series does not shunt transients to ground, but utilizes discrete mode circuitry to create a near equipotential bond amongst all conductors to dissipate surge energy. The units are all bi-directional enabling them to suppress any surges from ground between any connected phases.

This economical device has features that are not available in devices costing many times its price. Its compact size makes installation a breeze. **Maintenance Free** operation and **15 Year Unlimited Free Replacement Warranty** provide peace of mind. Standard unit is Type 2 10kA UL Nominal Discharge Current, Optional Type 2 20kA I_N is available

GENERAL	
Description:	Parallel connected, transient voltage surge suppressor device utilizing both high-energy handling and Frequency Attenuation Network® circuitry for virtual elimination of impulse and ring wave type transients. (tracking and monitoring the AC sine wave)
Application:	Designed for use at ANSI/IEEE Categories C, B and A with susceptibility up to medium exposure levels. Designed to protect sensitive/critical loads fed from distribution panels, branch panels and/or individual equipment panels.
Warranty:	15 Years Unlimited Free Replacement
Product Qualifications:	ANSI/UL 1449 Fourth Edition by CSA (MC# 259700) & UL – (ML#: E363345); UL1283* and CE Compliant (*Type 2 SPDs only) ISO 9001:2000, ANSI C62.72-2007, IEC 61643-1 Class 2&3

MECHANICAL	
Enclosure:	High strength ABS Plastic, IP 60, NEMA 1 rated enclosure.
Mounting:	3/4" conduit fitting (internally threaded) and external mounting feet.
Connection Method:	#10 stranded wire.
Shipping Weight:	≈6lbs

ELECTRICAL	
Circuit Design:	Parallel connected, internally fused, hybrid design incorporating all mode protection, and utilizing our encapsulated design to provide improved durability.
Protection Modes:	L-N, L-L (Normal Mode), and L-G, N-G (Common Mode). (Seven discrete modes)
Response Time:	< 1 nanosecond
Input Power Frequency:	50-60Hz constant (400hz w -V option)
EMI/RFI Noise Attenuation:	30dB Max. from 1kHz to 10MHz
Circuit Diagnostics:	Super Bright LED, 1 per phase, normally on.
Circuit Interrupt:	External and internal (see installation instructions for details).
Fusing:	Component Level Thermal and Board Level Current Fusing
kAIC Rating:	200 kAIC when installed according to installation instructions
Operating Temp/RH	Up to 80° C, 0 – 99% Relative Humidity Non-Condensing
Carrier Frequency	Not Applicable – Capacitance per mode < 20 nF
Options:	-V Remove Frequency Attenuation; -S Surge Counter; -C Dry Relay Contacts, -X3 Nema 4 Rating enclosure, Other options available. Call!

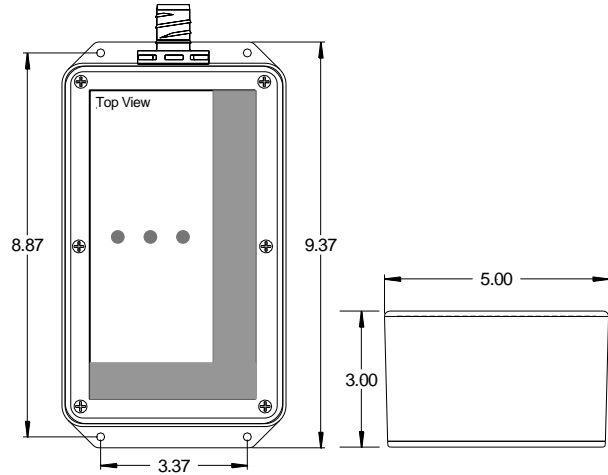

MEASURED LIMITING VOLTAGE PERFORMANCE AND ELECTRICAL SPECIFICATIONS

Model	Circuit Type	MCOV	Peak Surge Current (Amps) Per Mode/Phase	Mode	ANSI/IEEE C62.41 & C62.45 Let-Through Voltage Test Results		
					A1 2kV, 67A 100KHz Ring Wave 270° Phase Angle	Cat B3/C1 (6 kV, 3 kA) 90° Phase Angle	C3 20kV, 10kA Impulse Wave 90° Phase Angle
RM-ST1201P1	120V, Single Ø (2 wire + ground)	150 L-N 150 L-G 150 N-G	40,000 / 80,000	L-N L-G N-G	35 60 55	377 380 541	925 1200 1200
RM -ST1201S1	120/240V, Split Ø (3 wire + ground)	300 L-L 150 L-N 150 L-G 150 N-G	40,000 / 80,000	L-L L-N L-G N-G	75 35 60 55	576 377 380 541	1200 914 1200 1200
RM-ST1203Y1	120/208V, 3ØY (4 wire + ground)	300 L-L 150 L-N 150 L-G 150 N-G	40,000 / 80,000	L-L L-N L-G N-G	55 35 60 55	576 377 380 541	1200 914 1200 1200
RM -ST1201P2	240V, Single Ø (2 wire + ground)	320 L-N 320 L-G 320 N-G	40,000 / 80,000	L-N L-G N-G	60 80 55	560 588 941	1050 1290 1290
RM -ST1202N4	480V, Single Ø (2 wire + ground)	550 L-L 550 L-G	40,000 / 80,000	L-L L-G	140	792 792	1375 1375
RM -ST1203Y2	220/380V, 3ØY 277/480V, 3ØY (4 wire + ground)	550 L-L 320 L-N 320 L-G 320 N-G	40,000 / 80,000	L-L L-N L-G N-G	130 60 80 55	805 560 588 941	1400 1050 1400 1575
RM -ST1203N2	240V, 3ØΔ (3 wire + ground)	320 L-L 320 L-G	40,000 / 80,000	L-L L-G	96	636 638	1275 1275
RM -ST1203N4	380V, 3ØΔ 480V, 3ØΔ (3 wire + ground)	550 L-L 550 L-G	40,000 / 80,000	L-L L-G	140	792 792	1375 1375

Let-Through Voltage Test Environment: Positive Polarity. Time base=1ms. All voltages are peak (±10%). Surge voltages are measured from the insertion point of surge on the sine wave to the peak of the surge. All tests are Dynamic (voltage applied) except N-G which is static (no voltage applied). All tests were performed with 6 inches of lead length outside the device enclosure which simulates actual "as installed" performance.

Single-pulse, surge current capacities of 200,000 amps or less are determined by single-unit testing of all components within each mode. Present industry test equipment limitations require testing of individual components or sub-assemblies within a mode for single-pulse, surge current capacities over 200,000 amps.



Because we are constantly seeking to improve our products, specifications are subject to change at any time.

© 2015 ECS International Inc. Specification Last Changed 06/15 RM-ST120.doc