



P O Box 330607
Ft. Worth, TX 76163
Phone 817.483.8497
Fax 817.572.2242
E-mail: info@sinetamer.com

INSTALLATION INSTRUCTIONS MODEL: ST-SPT

WARNING - HAZARDOUS VOLTAGES ARE PRESENT. Improper installation may result in serious injury to the installer and/or damage to the electrical system or related equipment. Read all instructions before beginning the installation. Safety equipment must be used as prescribed by OSHA, whenever working around hazardous voltages.

Failure of unit and/or consequential equipment damage due to improper installation or misapplication is not covered by the product warranty.

Voltage measurements and **installation must be completed by a licensed/qualified electrician** in accordance with the National Electric Code, State, and Local codes. The National Electric Code, State and Local Code requirements supersede this instruction.

POWER MUST BE REMOVED FROM THE ELECTRICAL SYSTEM BEFORE INSTALLING THE ST-SPT UNIT.

INSTALLATION MATERIALS REQUIRED

The following is a list of materials that may be needed for proper installation of this surge suppression device. This list is intended to help the installer anticipate materials needed for a successful installation. The installer should become familiar with the scope of work to avoid lost time and improper installation. Failure to use fittings that are UL Listed will void the UL Listing and the Manufacturers warranty.

- Attachment Hardware: For plaster and sheet rock: Use (four ea.) TEK Screws or screws and anchor toggle bolts, flat washers and lock washers. For Wood or Metal use the appropriate screws, flat washers and lock washers.
- Connection: Use appropriately sized spade connectors or other positive connection hardware.
- Tools: Drill & bits, Torpedo Level, Screwdrivers, Appropriate Safety Equipment, etc.

WIRING DIAGRAM

The ST-SPT unit must be connected to the electrical system using one of the following types of circuit interrupt devices:

- 1 - Single Pole, 15 Amp Circuit Breaker or 15 Amp, Class RK5 Fuse (Bussmann FRN-15) for ST-SPT.

Note: Pre-existing breakers of the rated load size that are serving existing loads, may be utilized if the breaker is "Listed" for this application (see NEC J 10-14) and provided the owner/tenant has authorized multiple conductor termination.

The design of the ST-SPT provides superior protection for sensitive/critical equipment. This unit is designed for IEEE C62.41 Location Categories A. It is designed to be used in 50 to 60Hz applications and should not be used at locations where the voltage frequency exceeds 60 Hz.

INSTALLATION DIAGRAM

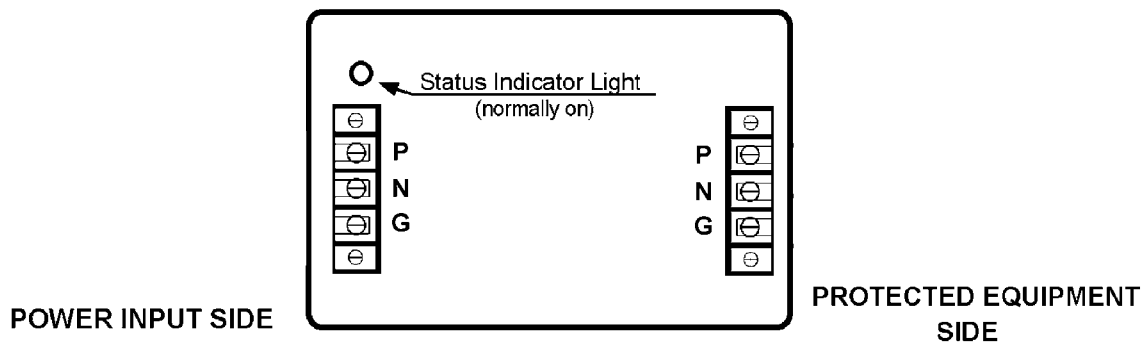

BEFORE INSTALLATION

Verify that system voltages are not in excess of the maximum suggested operating voltage levels listed in the table below. All voltage and current measurements should be made using a high quality RMS meter.

Do NOT install the device if the measured voltages exceed the maximum suggested operating voltage levels.

There are no position-oriented components in the ST-SPT unit; therefore, the device can be mounted upside down or sideways to allow for best installation.

Table of Maximum Suggested Operating Voltages and Unit's Wire Colors

Nominal System Voltage Single Phase	Phase To Neutral	Phase to Ground	*Neutral To Ground
120	125V	125V	<125V
240	300V	300V	<300V

**NOTE: If Neutral to Ground voltage is greater than 5 VAC, a problem may exist in the electrical system. The ST-SPT unit may be installed; however, a qualified electrician or Power Quality Engineer should be consulted to correct the problem. The neutral to ground voltage listed above is a requirement by UL.*

INSTALLATION STEPS

STEP 1: Check Voltages

- Confirm that the system voltage does not exceed the maximum suggested operating voltage. All voltage measurements should be completed with a RMS voltmeter. **DO NOT INSTALL THE ST-SPT UNIT IF THE MEASURED VOLTAGE EXCEEDS THE MAXIMUM SUGGESTED OPERATING VOLTAGE OF THE DEVICE.**

CAUTION: Do not proceed further until power has been removed from the electrical system.

STEP 2: Mounting the Unit

The ST-SPT is provided with terminals on both the input and output ends of the device. This allows a great degree of flexibility as to the location of the device. The suppressor should be located so that it is the last device in the circuit before the equipment to be protected. The device contains no position-oriented components therefore; the device can be mounted upside down or sideways but it should be mounted in such a way as to allow for the most separation between input and output wiring.

- Mechanically mount the ST-SPT. Secure the unit with screws, using the mounting feet of the enclosure.

STEP 3: Wire the ST-SPT into the Electrical System

- Cut all wires as short as necessary to facilitate a neat installation.
- Connect the incoming system GROUND wire to the (G) ground terminal on the input side.
- Connect the incoming system NEUTRAL wire to the (N) neutral terminal on the input side.
- Connect the incoming system PHASE wire to the (P) phase terminal on the input side. (This connection is to be made on the load side of the circuit interrupt)
- Repeat the connections on the Protected Equipment side of the suppressor.

*Before energizing, measure the voltage again to insure it is within the levels in the table above.
Immediate failure of the unit will occur if installed on voltages higher than these.*

STEP 4: Apply Power to the ST-SPT

- The LED indicator light should be illuminated. If it is not, remove power from the ST-SPT device and contact Energy Control Systems or your distributor by telephone at 1-817-483-8497 or e-mail at info@sinetamer.com